

NC-High pressure vice T-REX for 5 – Sided Machining

- safe and quick clamping of raw parts, thermal cut parts and sawn off material by embedding of hardened gripper studs in the workpiece
- optimal accessibility for 5- sided machining thanks to rigid and compact base allowing at the same time a large clamping width
- grip studs are easy adjustable
- different shapes of workpieces can be used thanks to the movable pivot jaw
- Clamping of pre-worked square workpieces by means of stepped jaws with carbide coating (optional)
- suitable for materials with strength value of approx. 900 N/mm² with the exception of hardened materials
- best utilisation of the available workspace = a lot of space for the workpiece

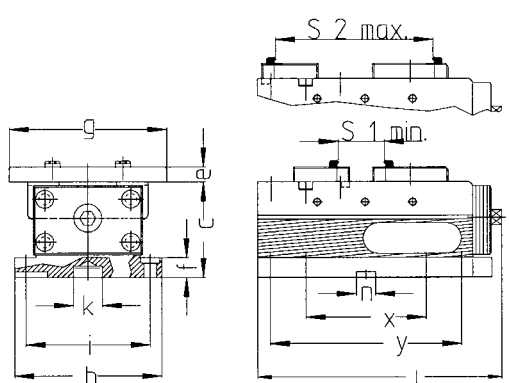

size	max. clamping force kN	max. torque Nm	weight kg	b mm	c -0,02 mm	e -0,03 mm	f mm
125	40	30	19	154	100	16	21

g mm	i mm	k H7 mm	L mm	n H7 mm	x mm	y mm	S1 min. mm	S2 max. mm
165	130	∅30	256	20	125,5	200	26	184



min. clamping width 26 mm



max. clamping width 184 mm



min. clamping width ∅ 65 mm



max. clamping width ∅ 226 mm

NC T-REX 125, order-no.: 2040/125

Scope of supply T-REX: vice incl. fix jaw and movable pivot jaw, 5 screwable grip studs with spiked ends, 1 wrench, 1 torque wrench, 4 fixture screws M12 x 35 mm

Technical details:

- Stable and compact base (GGG 60); width 125 mm
- Top- and bottom side is ground
- The spindle is entirely enclosed and nitrated – high reliability, best protection against swarf and chips, minimized cleaning time
- Clamping with torque wrench – max. 30 Nm
- Easy to operate with mechanical power intensifier
- Reversible fix jaw with 6 threads and movable pivot jaw with 8 threads for the screwable grip studs
- 3 threads per side for workpiece stop
- Accurate aligning slots and positioning hole on the bottom side
- Fixing possibility for M12 screws in the clamping shoulder

Accessories for NC-High pressure vice T-REX

Console T-REX for improvement of the accessibility by 5 – sided machining center in connection with NC T-REX 125

- Scope of supply: console incl. fixing bolts, 2 key ways, 4 screws

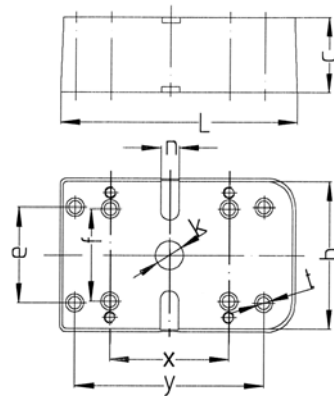

Console T-REX, order-no.: 2340/125

Size	b	L	c	e	f	n	k	t	x	y
mm	mm	mm	mm -0,02	mm	mm	mm H7	mm H7	mm	mm	mm
125	154	250	85	100	96	20	30	13	125,5	200

Stepped jaws for clamping of parallel pre-worked square workpieces

- Material: hardened steel, clamping surfaces are additionally carbide coated (80 Rockwell) for high grip factor, higher holding force by a minimum factor 1,5

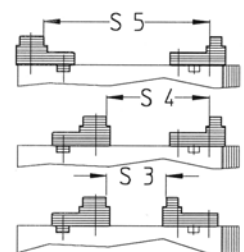
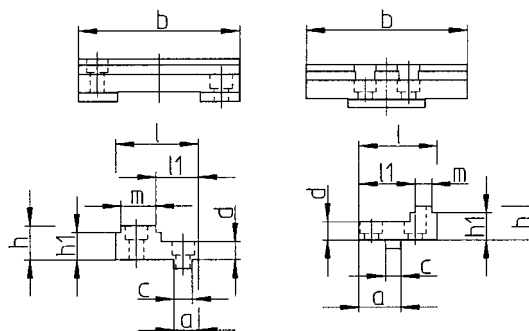

Stepped jaw fix, order-no.: 2330/125

Stepped jaw movable, order-no.: 2331/125

Stepped jaw fix

Stepped jaw movable

Dimension	a mm	b mm	c mm	d mm	h mm	h1 mm	l mm	l1 mm	m mm	S3 mm	S4 mm	S5 mm
carbide coated stepped jaw, fix	19	124,4	14	14	26	21	64	33	27	8-66	64-113	99-183
carbide coated stepped jaw, movable	32,5	124,4	12	14	26	21	60,5	43,5	13			

Jaws with reduced width 64 mm for 5 – sided machining

- allows an optimal access to the workpiece - ideal also for short tools
- for clamping small up to medium sized workpieces
- clamping of raw parts (also round parts) is possible by 2 adjustable gripper studs per jaw (Gripper studs are not included in the scope of delivery)
- smooth clamping surfaces for clamping of pre-worked square workpieces



Jaw fix, order-no.: 2310/125

Jaw movable, order-no.: 2311/125

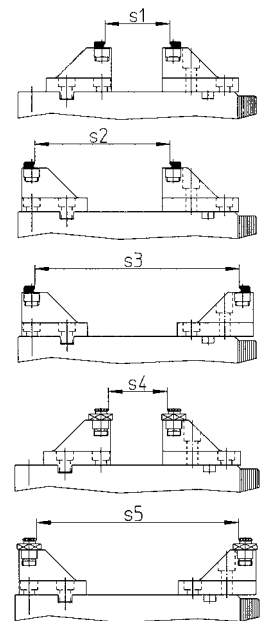
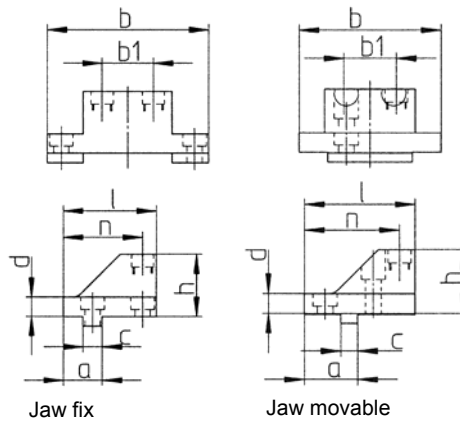

Dimension	a mm	b mm	b1 mm	c mm	d mm	h mm	l mm	n mm	s1 mm	s2 mm	s3 mm	s4 * mm	s5 * mm
Jaw, fix	28	116	37	14	14	45	67	57	19-67	61-137	128-208	15-59	120-200
Jaw, movable	37,5	96	37	12	14	45	78	67					

* by use of round grip studs, order-no.: 2303/000

Jaws with reduced width carbide coated 20 mm for clamping of pre-worked square workpieces and small workpieces

- further improved accessibility to workpiece thanks to narrow and high mounting form – ideal also for short tools
- clamping surfaces are additionally carbide coated (80 Rockwell) for high grip factor, higher holding force by a minimum factor 1,5



Jaw fix, order-no.: 2320/125

Jaw movable, order-no.: 2321/125

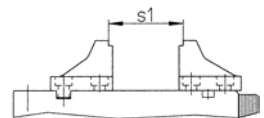
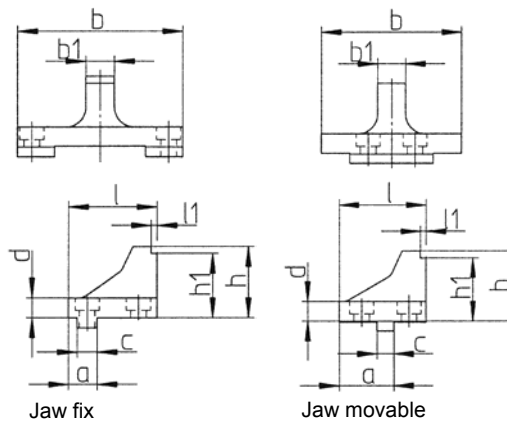

Dimension	a mm	b mm	b1 mm	c mm	d mm	h mm	h1 mm	l mm	l1 mm	S1 mm
Jaw, fix	20	116	20	14	14	50	45	62	4	9-74
Jaw, movable	39	96	20	12	14	50	45	62	4	

Grip studs – screw in

- grip stud inserts with spiked ends for machining of raw parts order-no.: 2301/000
- clamping insert flat carbide coated for clamping of pre-worked square workpieces order-no.: 2302/000
- round grip stud with spiked ends for machining of raw parts that provides 6 mm space under the workpiece. order-no.: 2303/000



Examples of use – T-REX



T-REX for 5 – sided machining and clamping of raw parts with the console. Further improved Accessibility to workpiece. Optional preparation for quick change systems.



High flexibility during machining thanks to the compact design of T-REX.



Trouble-free high stock removal performance also cross the clamping direction possible.



Multiple clamping on a pallet create new possibilities.



ALLMATIC – Jakob Spannsysteme GmbH
Jägermühle 10 D-87647 Unterthingau
Tel.: +49 (0) 8377 / 929 - 0
Fax: +49 (0) 8377 / 929 - 380

www.allmatic.de

info@allmatic.de

NC- High pressure vice T-REX XL for clamping of raw parts

- safe and quick clamping of raw parts, thermal cut parts and sawn off material by embedding of hardened gripper studs in the workpiece
- grip studs are easy adjustable
- different shapes of workpieces can be used thanks to the movable pivot jaw
- suitable for materials with strength value of approx. 900 N/mm^2 with the exception of hardened materials

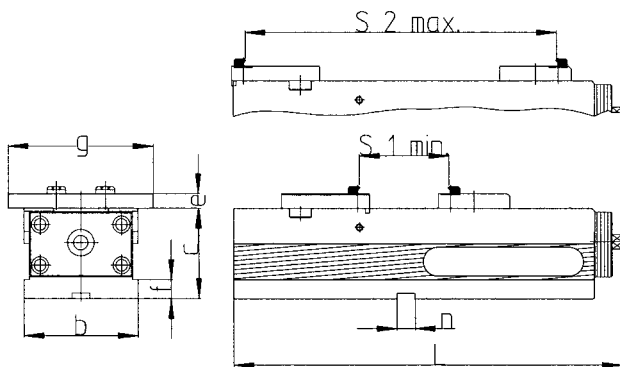

size	max. clamping force kN	max. torque Nm	weight kg	b mm	c -0,02 mm	e -0,03 mm
125	40	30	33	126	100	16

f mm	g mm	L mm	n H7 mm	S1 min. mm	S2 max. mm
21	165	430	20	26	365



min. clamping width 26 mm



max. clamping width 365 mm



min. clamping width \varnothing 65 mm

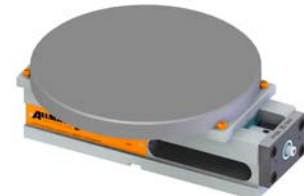

max. clamping width \varnothing 390 mm

NC T-REX XL 125, order-no.: 2043/125

Scope of supply T-REX XL: vice incl. fix jaw and movable pivot jaw, 5 screwable grip studs with spiked ends, 4 side clamps, 3 wrenches, 1 torque wrench

Technical details – T-REX XL:

- Stable and compact base (GGG 60)
- Top- and bottom side is ground
- The spindle is entirely enclosed and nitrated – high reliability, best protection against swarf and chips, minimized cleaning time
- Clamping with torque wrench – max. 30 Nm
- Easy to operate with mechanical power intensifier
- Reversible fix jaw with 6 threads and movable pivot jaw with 8 threads for the screwable grip studs
- 1 thread per side for workpiece stop
- Accurate aligning slots and positioning hole on the bottom side

Accessories for NC vice T-REX XL:

Additionally to basis jaws **fix (Order-No.: 2335)** and **movable (Order-No.: 2334)** which are included in the scope of supply of the vice, we offer following stepped jaws for T-REX XL:

Stepped jaws XL

- high and stepped side incl. threads for parallels
- additional thread on the high side for the HD jaws (see HD accessories)
- quick change system for parallels with click system



Stepped jaw XL fix, Order-No.: 2560/125
Stepped jaw XL movable, Order-No.: 2332/125

Size	a	f	g	m	n	x	y	S1	S2
mm	mm	mm	mm	mm	mm	mm	mm	mm	mm
125	398	108	24	180	20	36	127	0-182	137-319

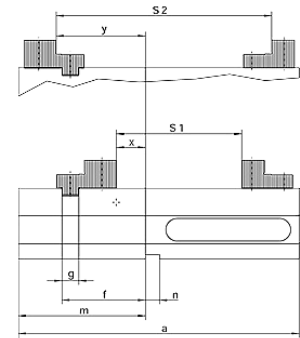

Console XL for improvement of the accessibility by 5 – sided machining center in connection with T-REX XL 125 as well as with NC Version LC, TC and LCH 125

- Optional preparation for quick change systems
- Scope of supply: console incl. fixing bolts, 2 key ways, 4 screws. 8 Duo side clamps. 4 screws

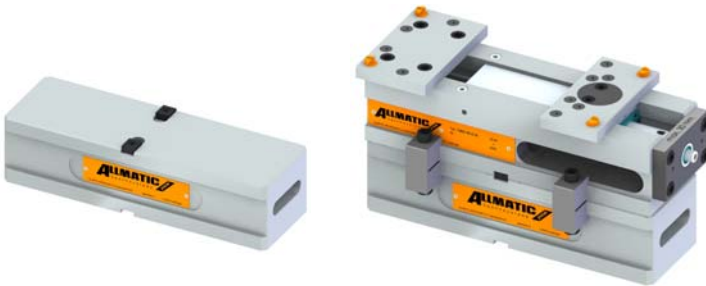

Console XL, order no.: 2343/125

Size	b	c	k	L	n
mm	mm	mm	mm (H7)	mm	mm (H7)
125	126	100	30	400	20

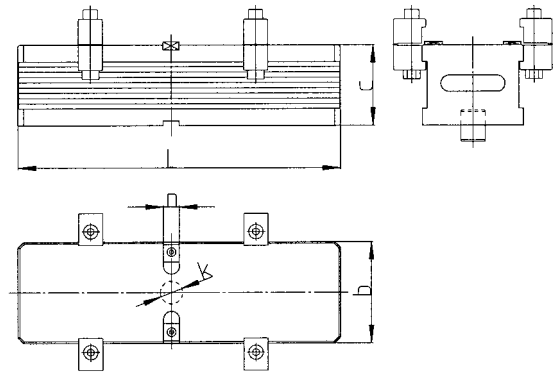

Grip studs – screw in

- grip stud inserts with spiked ends for machining of raw parts
order-no.: 2301/000
- clamping insert flat carbide coated for clamping of pre-worked square workpieces
order-no.: 2302/000
- round grip stud with spiked ends for machining of raw parts that provides 6 mm space under the workpiece.
order-no.: 2303/000



Aligning and fixing set for NC T-REX XL

- Scope of supply: 4 screws, 4 washers, 4 T-slot stones, 2 slot fixtures

Aligning und fixing set 12 mm:	order-no.: 2700/000
Aligning und fixing set 14 mm:	2701/000
Aligning und fixing set 16 mm:	2702/000
Aligning und fixing set 18 mm:	2703/000
Aligning und fixing set 20 mm:	2706/000
Aligning und fixing set 22 mm:	2707/000



ALLMATIC – Jakob Spannsysteme GmbH
Jägermühle 10 D-87647 Unterthingau
Tel.: +49 (0) 8377 / 929 - 0
Fax: +49 (0) 8377 / 929 - 380

www.allmatic.de

info@allmatic.de